

DIOCESE OF CHELMSFORD
DIOCESAN ADVISORY COMMITTEE



**SEATS AND BENCHES
IN CHURCHYARDS**

GUIDELINES TO ASSIST PARISHES

Revised March 2019

SEATS AND BENCHES IN CHURCHYARDS

I INTRODUCTION

- 1.1 Seats and benches have been common in churchyards, probably for centuries.
- 1.2 Benches (seats without backs) have probably the longest history and they are still frequently found in porches and lych-gates. One advantage of a bench is that it faces two ways and so does not have the directional emphasis of a seat.
- 1.3 Both provide for rest and quiet contemplation in areas which are traditionally detached from the hustle and bustle of the everyday world. Today seats are most frequently provided as memorials but occasionally, for instance in a cremated remains area, a seat is given by the church for the use of friends and relatives visiting the churchyard.

2 SITING

- 2.1 The site chosen needs to satisfy a number of functions:
 - (a) a quiet spot, away from traffic noise;
 - (b) a place where there is a pleasant prospect, perhaps over part of the churchyard or maybe over a wider prospect;
 - (c) the site should not be too shaded, either by the building or by trees and it would be preferable for the seat to have a southerly prospect;
 - (d) some shelter shielding from the north might be necessary on an open site.
- 2.2 It should be borne in mind that the seats will often be placed in prominent positions in the churchyard and so will contribute to the appearance of the church and its setting to the passing public. The

design should therefore be carefully chosen to ensure that this view of the church is enhanced.

3 MATERIALS

- 3.1** There are three traditional materials, timber, stone and metal (wrought or cast iron) and possible combinations of any two of these.
- 3.2** Timber seats are most common. Wood is a material which will be in harmony with any churchyard setting. Hardwood, left to weather or oiled, is best. Varnishes and other proprietary finishes will all deteriorate in time and experience shows that these finishes are unlikely to be maintained. The selection of hardwood is important both from a weathering and ecological point of view.
- 3.3** The DAC considers the environmental impact of all proposals and the origin of all timber is important. Various organisations (see appendix 1) will provide information on timber which can be obtained from renewable sources. English Oak will always be the first choice for a seat or bench in a parish churchyard.
- 3.4** Wrought or cast iron seats have advantages, in particular in so far as longevity is concerned. With minimum maintenance iron seats will last for 200 years.
- 3.5** A combination of an iron frame with hardwood slatted seat and back is a good compromise, providing the more comfortable seat which is replaceable, allied to the permanence of the iron frame.
- 3.6** Stone benches and seats are uncommon but, of all the materials, can be the most at home in a churchyard. The stone must be selected both for its weathering properties and its visual suitability. A stone similar to part of the church will be most apt. Failing that, a stone from the British Isles should be a priority. As with tombstones, exotic stones are out of place. Artificial stone may be acceptable but the design will need to be recommended by the DAC.

3.7 Seats and benches manufactured using recycled plastic are now increasingly available although their design is often of poor quality and not normally acceptable for use in a churchyard where the dignity of the space is paramount. Additionally, whilst they are often described as maintenance free, in reality they are impossible to ‘maintain’ once they start to degrade, e.g. they cannot be painted or oiled or re-lacquered. Whilst they may appear to be a sustainable option, they will not normally be recommended by an Archdeacon under delegated powers or by the DAC.

4 DESIGN

4.1 There is a fairly wide availability of off-the-peg timber benches most of which are of the sturdy local authority park bench type. Something more subtle and less of a standard pattern would be more appropriate in a churchyard and, where it can be afforded, a bespoke design will speak its individuality to its site.

4.2 Similarly off-the-peg light metal seats, usually cast aluminium with slatted seats, are found in garden centre catalogues, but these tend to be flimsy in appearance, more suited for a domestic garden than a churchyard, where something more robust is called for. Wrought iron would have to be purpose made. There is no reason why a modern design should not be used, but care should be taken to ensure that it is not of a type that is often seen in high streets. Some traditional patterns in cast iron are now available from manufacturers. Generally these take the form of seat ends to which are fitted timber slats, and these would usually be quite suitable in a churchyard.

5 INSCRIPTIONS

5.1 Most new seats are memorials, generally to individuals associated with the church and buried there. It is therefore fitting that an inscription or dedication should be incorporated.

- 5.2 Brevity should be the key. A name and two dates are often quite sufficient to indicate that that person is remembered in this place.
- 5.3 With a timber or stone seat a carved inscription is most suitable as it becomes part of the seat and will remain so. A well carved inscription along the back rail of a seat will not only be a memorial but will be an element of the design.
- 5.4 Cast metal plaques, which should be secretly fixed for security, are most common on timber seats, but they do have municipal connotations. On metal seats such plaques would have to be riveted. Brass is not acceptable for external use because it weathers badly.
- 5.5 Due to the increase of theft of metal, slate plaques can be considered as an alternative to bronze plaques.

6 FIXING AND SETTING

- 6.1 Sadly it is necessary to fix seats down very securely. However the “standard” method of setting the seat on a concrete base the size of the seat is visually quite unsuitable and should not be used in churchyards. The preferred method is to fix the legs to concrete blocks set below ground level. This is illustrated in appendix 2.
- 6.2 Thought should be given to the immediate setting of the seat. If only occasional use is likely, setting the seat in a grass sward would be ideal. Where more intensive use is possible a simple area of stone or brick paving would be suitable. In both these cases the surface finish would cover the concrete fixing base described above.

APPENDIX I

For advice on appropriate sources for timber:

Forestry Stewardship Council
FSC UK
11-13 Great Oak Street
Llanidloes
Powys
SY18 6BU
Email: info@fsc-uk.org
Website: www.fsc-uk.org

01686 413 916

Friends of the Earth
26-28 Underwood Street,
London
NI 7JQ.
Email: via website link
Website: www.foe.co.uk

020 7490 1555

Greenpeace UK
Canonbury Villas
London
NI 2PN
Email: via website link
Website: www.greenpeace.org.uk

020 7865 8100

The Rainforest Foundation UK
233A Kentish Town Road,
London
NW5 2JT
Email: info@rainforestuk.org
Website: www.rainforestfoundationuk.org

020 7485 0193

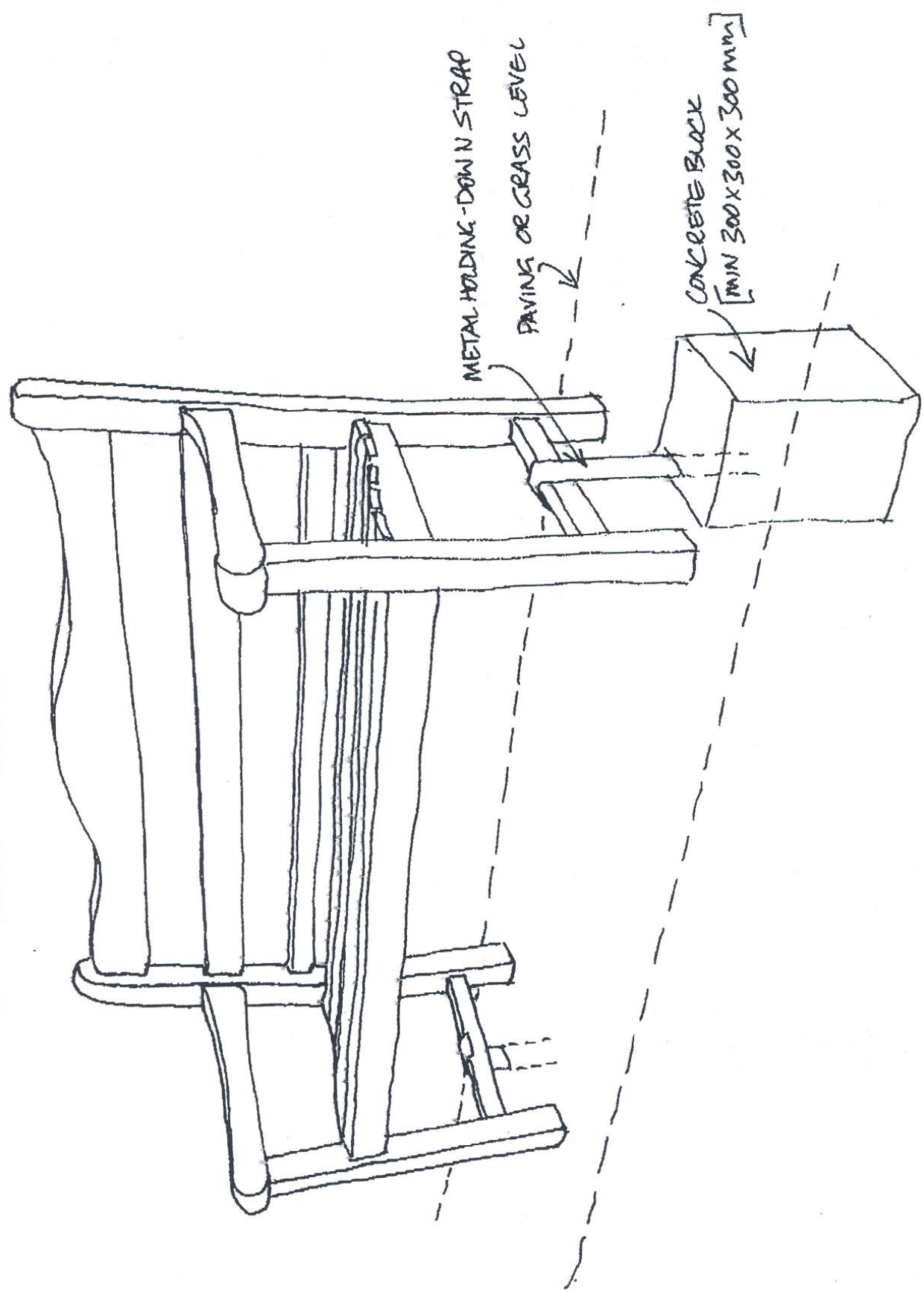

POLICY

1. Parishes and donors should consider commissioning purpose made designs rather than catalogue items so as to emphasise the individuality of each place.
2. The DAC will favour the use of traditional materials and will expect parishes to take into account environmental issues by selecting materials that are both environmentally friendly and in harmony with the setting.
3. Parishes should take care with both the design and wording of inscriptions. The former should be integral to the design of the seat; the latter should be suitably concise.
4. The fixing of seats should be discreet and the immediate setting should be in harmony with the churchyard.

**This is one of a series of guidelines published by the
Diocesan Advisory Committee**
Copies can be downloaded from the Diocesan website:
www.chelmsford.anglican.org/parishes/dac/dac_notes

**or can be obtained from the
DAC Secretary at the address below**

Diocesan Advisory Committee
Diocese of Chelmsford
53 New Street
Chelmsford
CMI IAT

Tel No: 01245 294400

